

innovative plastic mold solution for medical plastic part

Mold Details

Place of Origin:Shenzhen, China (Mainland)

Brand Name:ABIS

Shaping Mode:Plastic Injection Mould

Product Material:ABS,PEM,PA,PS,ETC

Product: Auto part

Product Color::White,Black,Red,Yellow,Blue etc.

Machine::CNC

CNC Machining Tolerance::0.003 to 0.005mm

Design software: STEP and X-T,UG,pro-E

Cavity:1 Cavity

Mold Life::50,000 to 1,000,000 shots

Mould Base:LKM,HASCO,DME

Runner:Hot/cold

Injection Mould running:Full automaticity

Injection Mould features:High classic very mature plastic
mould structure

Equipments: CNC, Electric Spark

Machine(WEDM-LS),Injection Machine

Mould Steel:NAK80,2738,2316,H13,718,S136,S136H ...







Injection molding:

Injection molding is used to produce thin-walled plastic parts for a wide variety of applications, one of the most common being plastic housings. Plastic housing is a thin-walled enclosure, often requiring many ribs and bosses on the interior. These housings are used in a variety of products including household appliances, consumer electronics, power tools, and as automotive dashboards. Other common thin-walled products include different types of open containers, such as buckets.

Injection molding is also used to produce several everyday items such as toothbrushes or small plastic toys. Many medical devices, including valves and syringes, are manufactured using injection molding as well.

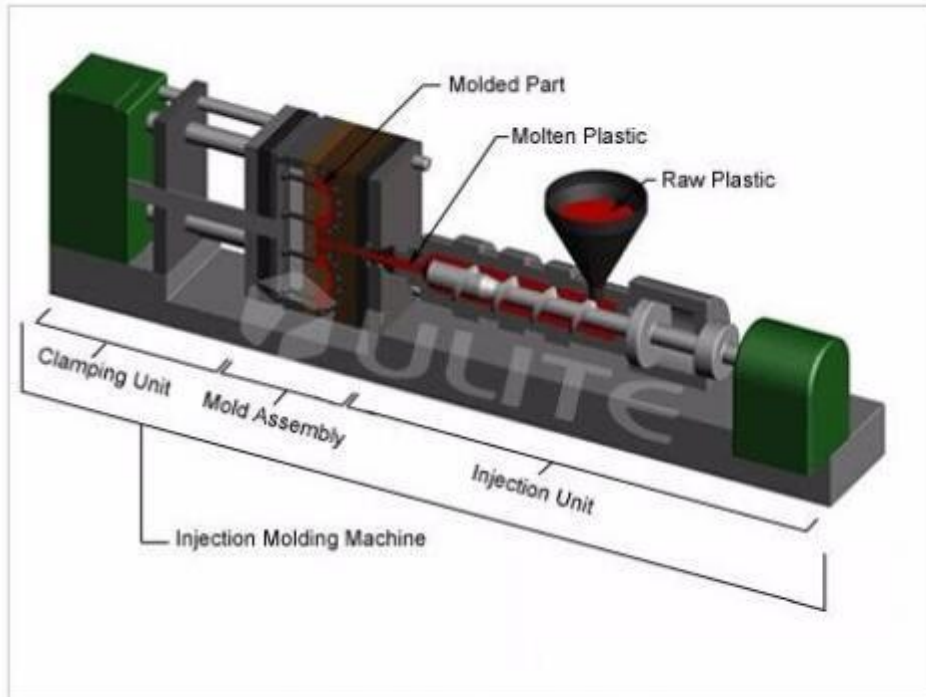

Injection molding overview

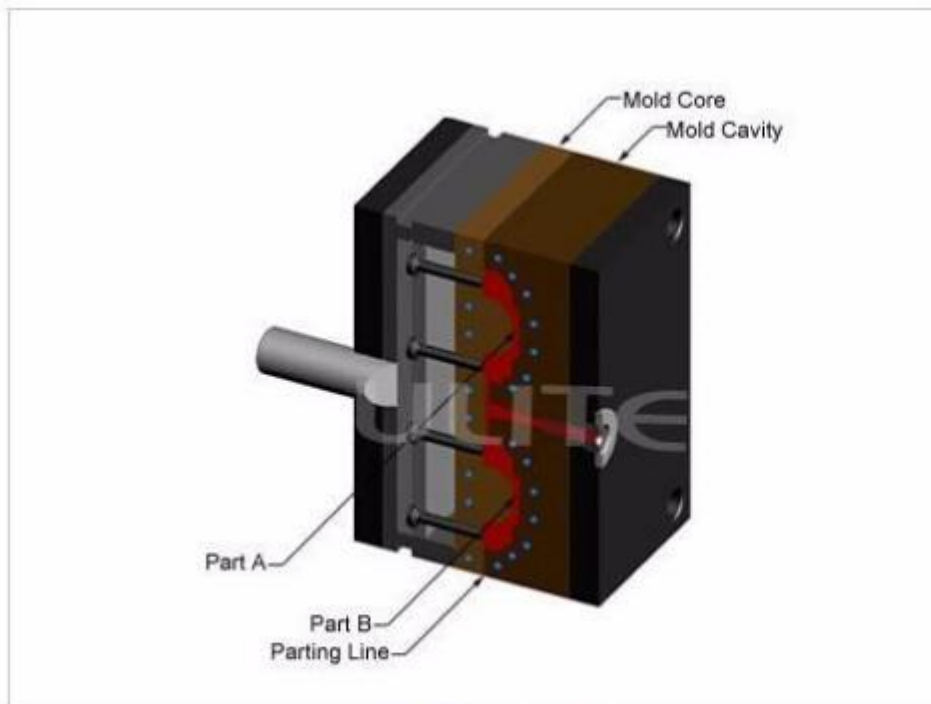

Mold overview

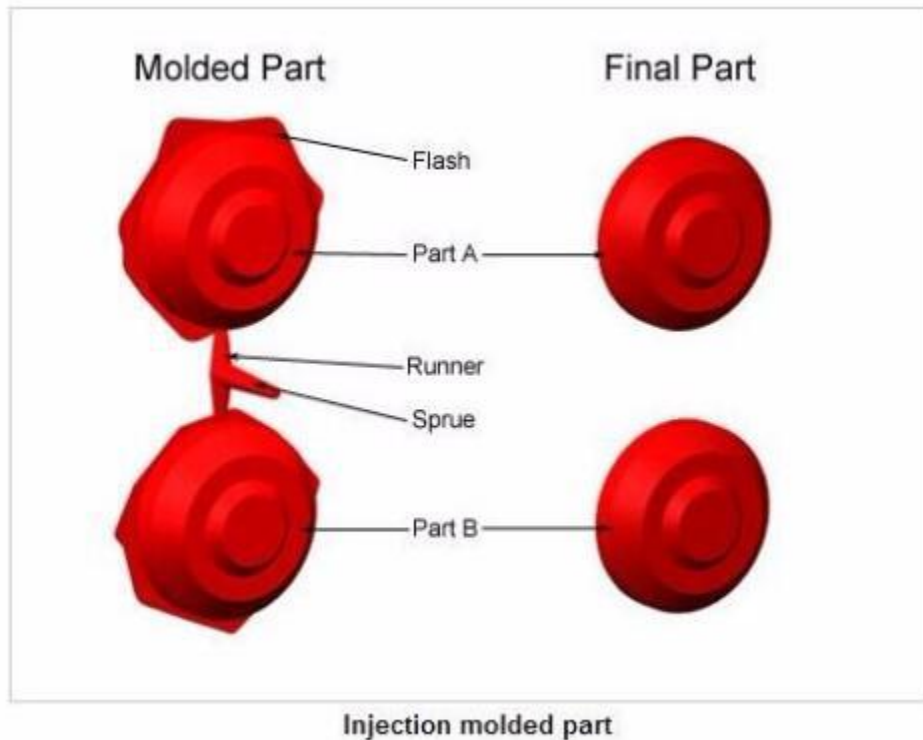

Know more about ABIS Tooling & Moulding

ABIS was founded in Shenzhen China, adjacent to Hong Kong, in 1996, has its own factory of 12,000 square meters. With the advanced facilities from Germany, Swiss and Japan, and a highly experienced design and engineering team, ABIS builds multi-cavity molds to exacting tolerances, providing the critical structural foundation for leading manufacturing companies to produce high precision mold.

Servicing various markets including Automotive & Aviation, Household & Industrial, Electronics &

Telecommunications, Medical & Healthcare, OA equipment, Consumer Packaging , Personal care, and Sports, ABIS helps clients optimize productivity and minimize manufacturing costs, strengthening the ability of OEM to compete effectively on a global basis.

Our highly skilled journeyman tool makers have been developing and passing down the intricate knowledge required to build tolerance critical tooling. Offering high-precision mold-making, molding capabilities coupled with expert design / engineering has helped position ABIS as the premier, full-service, plastic injection molder / mold-maker in China.

ABIS applies advanced software for mold design-Auto CAD, UG, Solid works and ProE etc. So far, ABIS has received the "ISO 9001" ,"ROHS" green, SGS certificate.





Something about Customized mold

1. Detailed description of Custom Plastic Mould:

Cavity/Core Material	718H,P20,NAK80,2316,2738,DI N2344,H13 and available
Product Material	ABS,PC,PP,PVC,POM,PMMA,P

	S,PE,PET,RUBBER Silicone,P A,PBT,PEI,etc
Base	LKM or by requested
Structure	Double Color injection mold,So lid Mold,Insert Mold,Mold with Slide,Mold with Lifter
Runner System	Hot runner,Cold runner
Cavity	Single cavity,multi cavity by re quested
Finish	Corrosion word,Mirror finish,Bru shed
Mold standard	HASCO,DME,MISUMI, or by re quested etc
Software	STEP and X-T,UG,pro-E
Tolerance	+/-0.05mm
Design time	5-7 day
Sample time	1 week
Production time	3-5 weeks,depends on mold st

	structure
Main technique	Milling,Grinding,EDM,Wire-cutting,Engraving,CNC etc
Longevity	0.5-1 million shots
Packing	Wooden case,PE,or by requested

2. Custom Plastic Mould making process

ABIS WORKING PROCESS

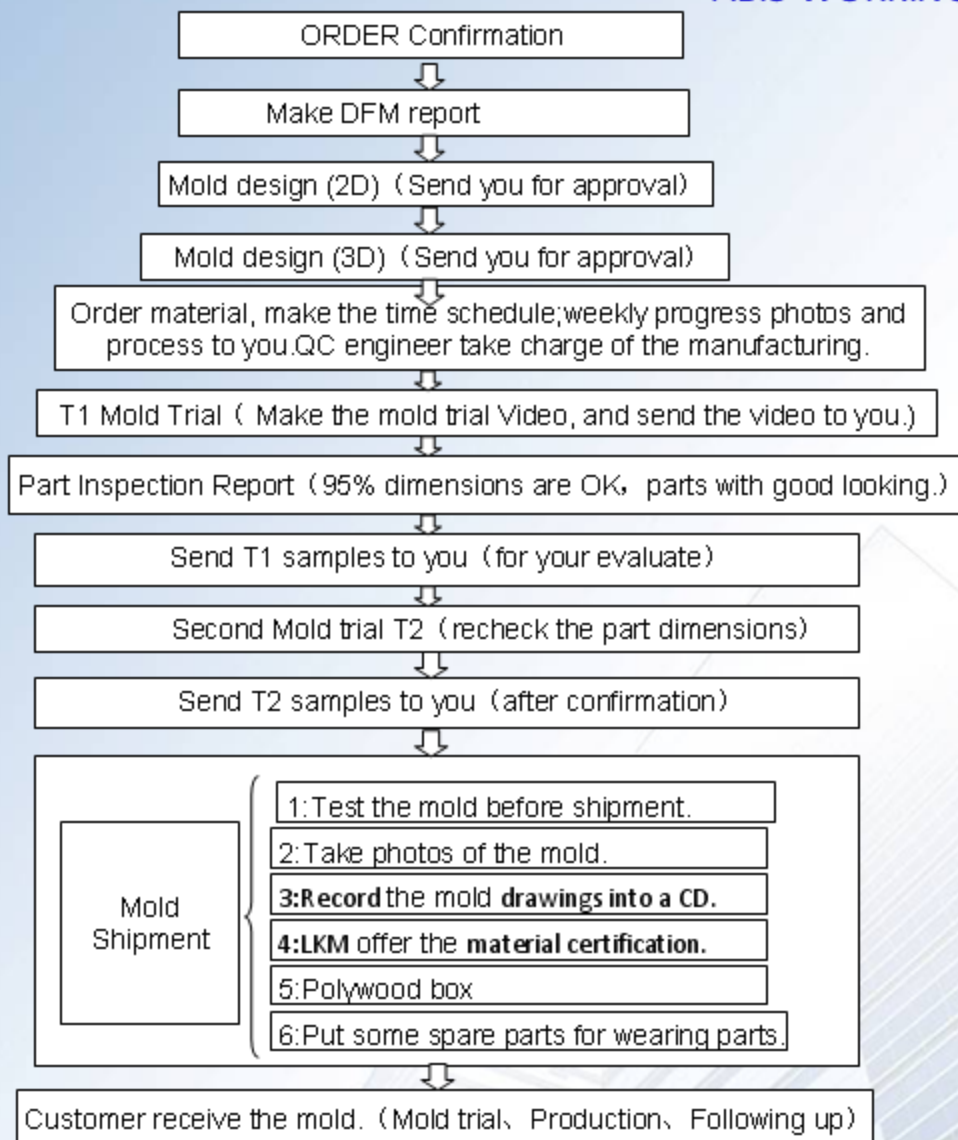

Some of Our products:







ABIS Mould packaging :



Mold Parking



OUR CERTIFICATE:



认证证书

此证书授予

深圳市艾比斯精密五金塑胶有限公司

认证地址：深圳市龙岗区龙岗街道龙东社区沙背坳福利工业园C栋一层

符合 ISO/TS 16949:2009 质量管理体系标准

认证范围：

塑胶制品（把手）的生产（不包括 7.3 产品设计）

注册号:	首次注册日期:	本次发证日期:
77463/A/0001/SM/2II	2017年1月3日	2017年1月3日
组织机构代码:	注册有效期:	IATF No:
91440300553884491N	2018年9月14日	0255825

发证人:  认证经理

本证书信息可在国家认证认可监督管理委员会官方网站 (www.cnca.gov.cn) 上查询。
URS (中国) 地址: Room 805, 806, Block 3, Tianyi International Building
of Huzhou street No. 588 in Hangzhou City, Zhejiang Province of China. 电话: 0571-86700691



Certificate of Registration

This certificate has been awarded to

Shenzhen ABIS Precision Hardware Plastic Co. Ltd

Floor1, Building C, Sha Bei Li Ying Keil Industrial Park LongDong Community, Longgang Street, LongGang District, Shenzhen City, Guangdong Province, China

in recognition of the organization's Quality Management System which complies with

ISO/TS 16949:2009

The scope of activities covered by this certificate is defined below

Manufacture of Plastic Parts (Handles) (Excludes Product Design under Clause 7.3)

Certificate Number:	Date of Issue of Certification Cycle:	
77463/A/0001/SM/En	03 January 2017	
Issue No:	Expiry Date:	IATF No:
1	14 September 2018	0255825

Issued by:  On behalf of the Schemes Manager





BEIJING HANGXIE CERTIFICATION CENTER CO.,LTD.
**QUALITY MANAGEMENT SYSTEM
CERTIFICATION**

ABIS MOLD TECHNOLOGY(HK)CO.,LTD

Organization Code: 55388449-1

No.102,Building B, Ying Keli Industry Area, Longgang District, Shenzhen,China. P.C 518116

is in conformity with

GB/T19001-2008 (ISO9001:2008)

This certificate is covering the following product scope

Plastic Mold Development and Manufacturing; Plastic Products Production

(Not Include the Products With Administrative Licensing)

Registration No. 03415Q20263R0M

The Duration of Validity :Feb . 10, 2015—Feb . 09, 2018



MANAGEMENT SYSTEM
CNAS C034-Q



General Manager: 

BEIJING HANGXIE
CERTIFICATION CENTER CO.,LTD.

FAQ:

FAQ

1. How many molds could you make every month?

Re: About 120 SETS

2. How about the largest mold you ever made?

Re: 2000mm*1600mm*1000mm

3. How about the tolerance?

Re: Mold tolerance 0.02mm,Product 0.02mm

4. Could you make double color injection mold?

Re: Yes

5. Have you ever made over mold?

Re: What type of materials you use? Yes,we have great experience in over mold of ABS+PC , PA + TPE ,TPE+TPE

6. How about the steel you usually use?

Re: We use steel of P20, P20H, 718H, NAK80, 1.2311, H13, 1.2344, 420SS, S136, S-7 and 1.2767.

They are from famous suppliers,such as LKM,ASSAB,THYSSEN and DAIDO.

7. How about the standard components you use?

Re: We only use standard components from LKM,DAIDO,HASCO,DME.

8. How long do you need for quotation?

Re: Exact quotation will be available within 1-2 working days once we get sufficient information from customer.

9. What do you need for quotation?

Re: We need 2D product drawing&3D file,or specific sample with detailed explanation and mold specification.

10. What is your turnaround time for injection mold building?

Re: Usually 3-5 weeks,it also depends on mold size and structure complexity.

We can overwork for your urgent project to shorten the delivery.

Contact me :

ABIS MOLD TECHNOLOGY CO., LTD

<http://www.abismold.com>

Cell/ Whatsapp/Wechat: 0086-183 7925 8646

Email/Skype: sunnys@abismold.com

Tel: +86-755-89984896 Ext 804

Fax: +86 -755-28960682

Add: Building B#, YingKeli Industrial Park, LongDong Community, LongGang District, S
518116